



ADNOC
DISTRIBUTION

AUTOMOTIVE

ADNOC GASOLINE / PETROL ENGINE OILS



* Table for general presentation, refer to products' respective data sheets for appropriate details

API	PRODUCT NAME	0W	0W	5W	0W	5W	10W	0W	5W	10W	15W	5W	20W	10W	REMARKS / COMMENTS
		16	20		30			40				50		60	
SP	ADNOC VOYAGER STAR PLUS ECO		✓	✓	✓	✓	✓								<ul style="list-style-type: none"> ILSAC GF-6A US (GM, Ford), JAP, KOR brands
	ADNOC VOYAGER STAR									✓	✓		✓		<ul style="list-style-type: none"> US, JAP, KOR brands
	ADNOC VOYAGER STAR PLUS HB	✓													<ul style="list-style-type: none"> Hybrid ILSAC GF-6B
SN+	ADNOC VOYAGER SILVER PLUS ECO		✓	✓	✓	✓	✓								<ul style="list-style-type: none"> ILSAC GF-5
	ADNOC VOYAGER GOLD RL			✓		✓									<ul style="list-style-type: none"> Ford Jaguar/Land Rover
SN	ADNOC VOYAGER BLUE			✓		✓			✓			✓		✓	<ul style="list-style-type: none"> Low SAPS. ACEA A1/B1, C3, C5
	ADNOC VOYAGER GOLD					✓		✓	✓						<ul style="list-style-type: none"> ACEA A3/B4 US, EU, JAP, KOR brands
	ADNOC VOYAGER SILVER						✓			✓					<ul style="list-style-type: none"> ACEA A3/B4 US, EU, JAP, KOR brands
SL	ADNOC VOYAGER BRONZE SPECIAL						✓				✓		✓		<ul style="list-style-type: none"> US, JAP, KOR brands 2004 & older
SJ	ADNOC VOYAGER SJ												✓		

ADNOC DIESEL ENGINE OILS



* Table for general presentation, refer to products' respective data sheets for appropriate details

API	PRODUCT NAME	10W	10W	15W	20W							REMARKS / COMMENTS
		30	40		20	50	10W	30	40	50	70	
CK-4	ADNOC VOYAGER SUPER PLUS HD	✓	✓	✓								<ul style="list-style-type: none"> • ACEA E9/E7, EURO VI (2017 and later) • Engines with Exhaust After-Treatment (DPF, EGR, and SCR)
CJ-4	ADNOC VOYAGER ULTRA			✓								<ul style="list-style-type: none"> • ACEA E9, EURO VI (2017 and later) • Engines with Exhaust After-Treatment (DPF, EGR, and SCR)
CI-4+	ADNOC VOYAGER PLUS HD	✓	✓	✓								<ul style="list-style-type: none"> • ACEA E7, EURO V • Engines with Exhaust After-Treatment (EGR, and SCR)
	ADNOC VOYAGER HD LONG DRAIN		✓									<ul style="list-style-type: none"> • Fully Synthetic. ACEA E4/E7, EURO V • Engines with Exhaust After-Treatment (EGR, and SCR) • NOT recommended for engines fitted with DPF
CI-4	ADNOC VOYAGER ULTRA SYN		✓									<ul style="list-style-type: none"> • Fully Synthetic. ACEA E6/E7, EURO VI (2017 and later) • Engines with Exhaust After-Treatment (DPF, EGR, and SCR)
	ADNOC VOYAGER ULTRA SEMISYN		✓									<ul style="list-style-type: none"> • Semi Synthetic. ACEA E4/E7, EURO V • Engines with Exhaust After-Treatment (EGR, and SCR) • NOT recommended for engines fitted with DPF
	ADNOC VOYAGER PLUS	✓	✓	✓		✓			✓	✓		<ul style="list-style-type: none"> • ACEA E7, EURO V • Engines with Exhaust After-Treatment (EGR, and SCR)
CH-4	ADNOC VOYAGER HPSD PLUS			✓		✓			✓	✓		<ul style="list-style-type: none"> • Mineral base oil. Older units (2002 and earlier)
CG-4	ADNOC VOYAGER HPSD			✓		✓		✓	✓	✓		<ul style="list-style-type: none"> • Mineral base oil. Obsolete, Older Units (2009 or earlier)
CF / CF-4	ADNOC HD CF (CF-4)			✓	✓	✓	✓	✓	✓	✓	✓	<ul style="list-style-type: none"> • Mineral base oil monograde – API CF • Mineral base oil multigrade – API CF-4

ADNOC AUTOMOTIVE TRANS / GEAR OILS



* Table for general presentation, refer to products' respective data sheets for appropriate details

API	PRODUCT NAME	75W		80W	85W		80W								REMARKS / COMMENTS
		80	90	90	90	140		90	140	10W	30	40	50	60	
GL-5	ADNOC Gear Oil SX	✓	✓												NOT recommended for GL-4 M/T w/ yellow metal synchronizers
	ADNOC Gear Oil GX LS			✓				✓							Limited Slip Differential Oil
	ADNOC Gear Oil GX			✓	✓	✓	✓	✓	✓						NOT recommended for GL-4 M/T w/ yellow metal synchronizers
GL-4	ADNOC Gear Oil GP			✓	✓	✓	✓	✓	✓						
	ADNOC HD Trans									✓	✓	✓	✓		<ul style="list-style-type: none"> • API CF • Caterpillar TO-2
	ADNOC Transmission Oil T4									✓	✓	✓	✓	✓	<ul style="list-style-type: none"> • API CF • Allison C-4 (SAE 10W, 30) • Caterpillar TO-4 • Komatsu KES 07.868.1 • ZF TE-ML-03C (SAE 10W, 30) • ZF TE-ML-07F (SAE 30)

ADNOC AUTOMATIC TRANSMISSION FLUIDS



* Table for general presentation, refer to products' respective data sheets for appropriate details

ADNOC ATF Universal	ADNOC ATF Dexron III-H	ADNOC ATF Dexron II-D	ADNOC CVT Fluid	ADNOC DCT Fluid
<ul style="list-style-type: none"> • Allison C-4, TES 389 and TES 295 • Chrysler ATF+4 • Ford Mercon® V • GM Dexron® III-H, GM Dexron®-VI • JASO 1A • Ford Mercon® LV • Hyundai SP-IV • Mazda FZ • MB 236.14 / 236.15 / 236.17 • Nissan Matic S • Shell M-1375.4 or ZF Lifeguardfluid6 • Shell M-1375.6 or ZF Lifeguardfluid6+ • Shell M-1375.8 or ZF Lifeguardfluid8; • Toyota Type WS 	<ul style="list-style-type: none"> • Allison C-4, TES 389 • GM Dexron® III-H • Ford Mercon® 	<ul style="list-style-type: none"> • Allison C-4 • GM Dexron® II-D • GM Type 'A' Suffix 'A' (TASA) 	<ul style="list-style-type: none"> • Daihatsu AMMIX CVT; CVTF DTC; CVTF-D FE* • Dodge/Jeep NS- 2; CVTF+4 • Ford CVT 30; CVT 23 • GM/Saturn DEX-CVT • Honda HCF2 • Hyundai/ Kia SP CVT 1 • Mazda CVTF 3320 • Mercedes Benz 236.20 • Mitsubishi CVT-J1; CVT-J4* • Nissan NS-1; NS- 2; NS-2V; NS-3 • Subaru Lineartronic CVTF/CVTF II; HT CVTF; CV-30; e-CFTV • Suzuki TC; NS- 2; VTF 3320; CVT Green 1/2*/3 • Toyota TC; FE* • VW/Audi TL 52180; G 052 180 (-A2); G 052 516 A2 	<p>VW/Audi/Skoda</p> <ul style="list-style-type: none"> • DCT DQ250 and DQ500 transmissions • DCTF-wet clutch VW P/N G 052 182 A2 (fluid ref.) <p>Getrag</p> <ul style="list-style-type: none"> • DCT 7DCT600 transmissions • DCTF-wet clutch BMW P/N 83220440214 (fluid ref.)

ADNOC MOTORCYCLE OILS



* Table for general presentation, refer to products' respective data sheets for appropriate details

Engine	Type	API	JASO	PRODUCT NAME	10W			15W	20W		REMARKS / COMMENTS
					30	40	60	50	40	50	
2T		TC	FD	Supreme Plus 2T Engine Oil							<ul style="list-style-type: none"> ISO L-EGD Motorcycles, Scooters, Lawn mowers, etc..
		TC	FD	Supreme 2T Engine Oil							<ul style="list-style-type: none"> ISO L-EGD Motorcycles, Scooters, Lawn mowers, etc..
4T	2-Wheel	SN	MA MA2	ADNOC Voyager MPX4-N			✓				<ul style="list-style-type: none"> Fully synthetic Severe duty Engine, Clutch and Gear (ECG) Applications
		SN	MA MA2	ADNOC Voyager MPX4-N	✓	✓					<ul style="list-style-type: none"> Fully synthetic Engine, Clutch and Gear (ECG) Applications Honda, Suzuki, Kawasaki, Yamaha, Bajaj
		SN	MA MA2	ADNOC Voyager MPX4-N				✓		✓	<ul style="list-style-type: none"> Synthetic-blend for long drain Engine, Clutch and Gear (ECG) Applications Honda, Suzuki, Kawasaki, Yamaha, Bajaj
		SL	MA MA2	ADNOC Voyager MPX4-L	✓	✓			✓	✓	<ul style="list-style-type: none"> Synthetic base Engine, Clutch and Gear (ECG) Applications Honda, Suzuki, Kawasaki, Yamaha, Bajaj
		SG		ADNOC Voyager MPX4-G						✓	<ul style="list-style-type: none"> Engine, Clutch and Gear (ECG) Applications Honda, Suzuki, Kawasaki, Yamaha, Bajaj
		SF		ADNOC Voyager MPX4-F						✓	<ul style="list-style-type: none"> Engine, Clutch and Gear (ECG) Applications Honda, Suzuki, Kawasaki, Yamaha, Bajaj
	Scooter	SN	MB	ADNOC Voyager SPX4-N	✓	✓			✓		<ul style="list-style-type: none"> Fully synthetic for Belt-type CVT models from Honda, Yamaha
		SL	MB	ADNOC Voyager SPX4-L	✓	✓			✓		<ul style="list-style-type: none"> Fully synthetic for Belt-type CVT models from Honda, Yamaha
	3-Wheel	SL	MA MA2	ADNOC Voyager 3-Wheeler Special Plus CP						✓	<ul style="list-style-type: none"> Synthetic base for Air/liquid cooled gasoline engines City driving, highway, or under harsh conditions



ADNOC
DISTRIBUTION

INDUSTRIAL

ADNOC HYDRAULIC OIL



* Table for general presentation, refer to products' respective data sheets for appropriate details

PRODUCT NAME	10W	10	15	22	32	46	68	100	150	REMARKS / COMMENTS
ADNOC Hydraulic Oil HP			✓	✓	✓	✓	✓	✓		<ul style="list-style-type: none"> High Performance High Viscosity Index in critical applications where viscosity variation due to temperature is critical.
ADNOC Hydraulic Oil ZF			✓		✓	✓	✓	✓		<ul style="list-style-type: none"> Zinc-free (typical: 10ppm max) For older design hydraulic pumps containing silver or silver-plated parts. Moderate to severe conditions in mobile and industrial service Suitable in environmentally sensitive applications
ADNOC GII Hydraulic Oil H				✓	✓	✓	✓	✓		<ul style="list-style-type: none"> Group II base oil. High Oxidation Resistance for longer oil life under severe working conditions
ADNOC Hydraulic Oil H		✓	✓	✓	✓	✓	✓	✓	✓	<ul style="list-style-type: none"> Premium mineral base oil. For most types of hydraulic systems, moderately loaded gears and bearing lubricated by circulation bath and ring oiling.
ADNOC Hydraulic Oil HD	✓									<ul style="list-style-type: none"> Premium mineral base oil. For general hydraulic applications requiring rust and oxidation inhibited, anti-wear hydraulic fluids

ADNOC INDUSTRIAL GEAR OIL



* Table for general presentation, refer to products' respective data sheets for appropriate details

PRODUCT NAME	22	32	46	68	100	150	220	320	460	680	1000	1500	REMARKS / COMMENTS
SYNGEAR PG							✓	✓	✓	✓			Synthetic (PAG) <ul style="list-style-type: none"> • DIN 51517 Part 3 (Group CLP) • NF-ISO 6743-6 (CKS/CKT category) • David Brown • CMD
ADNOC SYNGEAR PA					✓	✓	✓	✓	✓				Synthetic (PAO) <ul style="list-style-type: none"> • DIN 51517 Part 3 (Group CLP) • NF-ISO 6743-6 (CKD category) • US STEEL 224 • CINCINNATI MILACRON • DAVID BROWN
ADNOC Industrial Gear Oil EP				✓	✓	✓	✓	✓	✓	✓	✓	✓	High Performance Mineral <ul style="list-style-type: none"> • DIN 51517 PART3 • AGMA 9005-D94 • US Steel 224 • David Brown S1.53 101
ADNOC Compounded Gear Oil										✓			High Performance Mineral <ul style="list-style-type: none"> • Worm gear drives • Steam engine cylinders and valves.
ADNOC Circulating Oil	✓	✓	✓	✓	✓	✓	✓	✓	✓				High Performance Mineral <ul style="list-style-type: none"> • Journal bearings, industrial hydraulic, bearings • Industrial gears not requiring heavy duty oils
ADNOC Grease OGL 5500													<ul style="list-style-type: none"> • Open Gear Oil application • ISO VG 5500

ADNOC AIR COMPRESSOR OIL



* Table for general presentation, refer to products' respective data sheets for appropriate details

PRODUCT NAME	15	32	46	68	100	150	REMARKS / COMMENTS
ADNOC Compressor Oil PA	✓	✓	✓	✓	✓	✓	<ul style="list-style-type: none"> • Synthetic PAO <ul style="list-style-type: none"> ○ High cost, Longer oil life ○ Compatible with mineral oils ○ Compatible with most seals & elastomers ○ Compatible with most paints & coatings • ISO 6743-3 DAJ for heavy duty applications • DIN 51506 VDL
ADNOC Compressor Oil PG					✓		<ul style="list-style-type: none"> • Synthetic PAG <ul style="list-style-type: none"> ○ High cost, Longer oil life ○ Incompatible with mineral oils ○ Refer to OEM for compatibility with seals & elastomers ○ Refer to OEM for compatibility with paints & coatings ○ High affinity with water ○ Recommended for Hydrocarbon Gas compression • Liquid ring vacuum pumps, rotary and screw compressors • Reciprocating Compressors – single-stage, two-stage, and multistage
ADNOC Compressor Oil		✓	✓	✓	✓	✓	<ul style="list-style-type: none"> • High Performance Mineral Oil <ul style="list-style-type: none"> ○ Low cost, Average oil life • Rotary and reciprocating compressors • Stationary and mobile applications. • Air discharge temperature up to 220°C • Vacuum pumps • DIN 51506 VD-L

VISCOSITY CLASSIFICATIONS – ISO



ISO VG	Spindle	Slideway	Heat Transfer	Circulating	Refrigeration
10	Spindle Oil 10				
15	Spindle Oil 15				
22	Spindle Oil 22		Heat Transfer Fluid GII 22	Circulating Oil 22	
32		Slideway Oil 32	Heat Transfer Fluid GII 32	Circulating Oil 32	Refrigeration Oil AB 32 (R22, R502) Refrigeration Oil PE 32 (R134a, R404a, R410a, R12, R22)
46		Slideway Oil 46		Circulating Oil 46	Refrigeration Oil AB 46 (R22, R502) Refrigeration Oil PE 46 (R134a, R404a, R410a, R12, R22)
68		Slideway Oil 68		Circulating Oil 68	Refrigeration Oil F 68 (R600a, R717, R12, R22) Refrigeration Oil AB 68 (R22, R502) Refrigeration Oil PE 68 (R134a, R404a, R410a, R12, R22)
100		Slideway Oil 100		Circulating Oil 100	Refrigeration Oil AB 100 (R22, R502) Refrigeration Oil PE 10 (R134a, R404a, R410a, R12, R22)
150		Slideway Oil 150		Circulating Oil 150	Refrigeration Oil AB 150 (R22, R502)
220		Slideway Oil 220		Circulating Oil 220	Refrigeration Oil PE 220 (R134a, R404a, R410a, R12, R22)
320				Circulating Oil 320	
460				Circulating Oil 460	

ADNOC GREASES



NLGI #	Product Name	Base Oil Type, Viscosity	Thickener + Additive	Comments / Remarks
00	ADNOC Grease EP 00	Mineral, 219	Lithium + EP	High Pressure
0	ADNOC Grease MP 0	Mineral, 220	Lithium	General Application
	ADNOC Grease EP 0	Mineral, 219	Lithium + EP	High Pressure
1	ADNOC Grease MP 1	Mineral, 220	Lithium	General Application
	ADNOC Grease EP 1	Mineral, 219	Lithium + EP	High Pressure
1.5	ADNOC Grease PA 460 1.5	Synthetic – PAO, 460	Lithium Complex	Wide temperature + High Load + Water Presence
2	ADNOC Grease PA 220 2	Synthetic – PAO, 220	Lithium Complex	Wide temperature + High Load + Water Presence
	ADNOC Grease MP 2	Mineral, 220	Lithium	General Application
	ADNOC Grease EP 2	Mineral, 219	Lithium + EP	High Pressure
	ADNOC Grease Moly EP (LF) 2	Mineral, 219	Lithium + EP	High Pressure
	ADNOC Grease Moly MP 2	Mineral, 220	Lithium + Moly	High Load
	ADNOC Grease HTB 2	Mineral, 92.5	Lithium + EP	High temperature + High Pressure
	ADNOC Grease LX 2	Mineral, 190	Lithium Complex	General Application + Water Presence
	ADNOC Grease LX EP 2	Mineral, 190	Lithium Complex + EP	High Pressure + Water Presence
3	ADNOC Grease LX 3	Mineral, 190	Lithium Complex	Water Presence
	ADNOC Grease LX EP 3	Mineral, 190	Lithium Complex + EP	Water Presence + High Pressure
	ADNOC Grease MP 3	Mineral, 220	Lithium	General Application
	ADNOC Grease EP 3	Mineral, 219	Lithium + EP	High Pressure

SEGMENT-SPECIFIC LUBRICATION

SEGMENT-SPECIFIC LUBRICATION

CEMENT

CEMENT



Raw Mill Section

Raw Material / Quarry Section

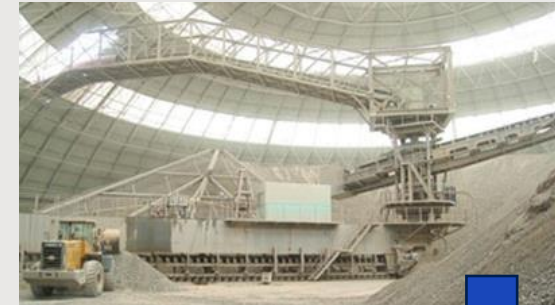
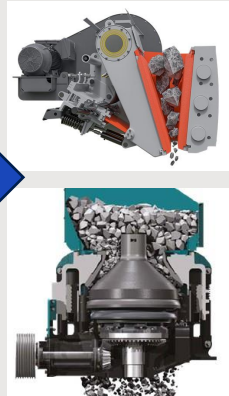

Kiln



Grinding / Blending Section



Cement / Finishing Mill



CEMENT – RAW MATERIAL / QUARRY SECTION



#	Equipment	Component	Best	Better	Remarks
1	Mobile Equipment	Engine	ADNOC VOYAGER ULTRA 15W-40	ADNOC VOYAGER PLUS 15W-40	SAE 15W-40 or as specified by OEM/EB
2		Hydraulic	ADNOC Hydraulic Oil HP	ADNOC Hydraulic Oil H	ISO VG 46, 68, 100
3		Transmission	ADNOC Gear Oil SX	ADNOC Gear Oil GX	Refer to OEM/EB Specification
4		Differential Drive	ADNOC Gear Oil SX	ADNOC Gear Oil GX	Refer to OEM/EB Specification
5		Final Drive	ADNOC Gear Oil SX	ADNOC Gear Oil GX	Refer to OEM/EB Specification
6		Grease Points	ADNOC Grease PA 220 2	ADNOC Grease EP 2	
7		Grease Points - Moly	ADNOC Grease Moly MP 2		
8	Rock Drills	Gear Drive / Gearbox - Oil (Worm)	ADNOC SynGear PG	ADNOC Compounded Gear Oil	ISO VG 320, 460
9		Gear Drive / Gearbox - Oil	ADNOC SynGear PA	ADNOC Industrial Gear Oil EP	ISO VG 150, 220, 320, 460
10	Rock Drills - Pneumatic	Rock drills and Hammer	ADNOC Rock Drilling Oil		ISO VG 100, 150,220
11	Conveyors	Gear Drive / Gearbox - Oil	ADNOC SynGear PA	ADNOC Industrial Gear Oil EP	ISO VG 150, 220
12		Gearbox - Grease	ADNOC Grease OGL GAX 500		OGL Viscosity is ~500 CSt

CEMENT - RAW MILL SECTION



#	Equipment	Component	Best	Better	Remarks
13	Crushers	Electric Motor Bearing	ADNOC Grease PA 220 2	ADNOC Grease EP 2	
14		Gear Drive / Gearbox - Oil	ADNOC SynGear PA	ADNOC Industrial Gear Oil EP	ISO VG 220, 320, 460
15		Bearing - Oil	ADNOC SynGear PA	ADNOC Industrial Gear Oil EP	ISO VG 150, 220
16		Hydraulic	ADNOC Hydraulic Oil HP	ADNOC Hydraulic Oil H	ISO VG 46, 68, 100
17	Conveyor	Electric Motor Bearing	ADNOC Grease PA 220 2	ADNOC Grease EP 2	
18		Gear Drive / Gearbox - Oil	ADNOC SynGear PA	ADNOC Industrial Gear Oil EP	ISO VG 150, 220
19		Bearing - Grease	ADNOC Grease PA 220 2	ADNOC Grease EP 2	
20		Coupling - Grease	ADNOC Grease OGL GAX 1000		OGL Viscosity is ~1000 CSt
21	Stacker/Reclaimer	Electric Motor Bearing	ADNOC Grease PA 220 2	ADNOC Grease EP 2	
22		Gear Drive / Gearbox - Oil	ADNOC SynGear PA	ADNOC Industrial Gear Oil EP	ISO VG 150, 220, 320
23		Bearing - Grease	ADNOC Grease PA 220 2	ADNOC Grease EP 2	
24		Open Gear	ADNOC Grease OGL GAX 500		OGL Viscosity is ~500 CSt
25		Cable	ADNOC OGL & WR Compound		

CEMENT - GRINDING/BLENDING SECTION



#	Equipment	Component	Best	Better	Remarks
26	Roller Press	Gear Drive / Gearbox - Oil	ADNOC SynGear PA	ADNOC Industrial Gear Oil EP	ISO VG 220, 320, 460
27		Bearing - Grease	ADNOC Grease PA 220 2	ADNOC Grease EP 2	
28	Ball Mill	Electric Motor Bearing	ADNOC Grease PA 220 2	ADNOC Grease EP 2	
29		Plain Bearing - Oil	ADNOC SynGear PA	ADNOC Industrial Gear Oil EP	ISO VG 150, 220
30		Gear Drive / Gearbox - Oil	ADNOC SynGear PA	ADNOC Industrial Gear Oil EP	ISO VG 220, 320, 460
31		Open Gear	ADNOC Grease OGL GAX 500		OGL Viscosity is ~500 CSt
32		Trunnion/Thrust/Pinion Bearing	ADNOC SynGear PA	ADNOC Industrial Gear Oil EP	ISO VG 150, 220, 320, 460
33		Fan Bearing - Grease	ADNOC Grease LX EP 2	ADNOC Grease EP 2	
34		Coupling - Grease	ADNOC Grease OGL GAX 1000		OGL Viscosity is ~1000 CSt
35		Speed Reduction Gearbox	ADNOC SynGear PA	ADNOC Industrial Gear Oil EP	ISO VG 150, 220, 320
36	Roller Mill - Horizontal	Gear Drive / Gearbox - Oil	ADNOC SynGear PA	ADNOC Industrial Gear Oil EP	ISO VG 220, 320, 460
37		Open Gear	ADNOC Grease OGL GAX 500		OGL Viscosity is ~500 CSt
38	Roller Mill - Vertical	Electric Motor Bearing	ADNOC Grease PA 220 2	ADNOC Grease EP 2	
39		Gear Drive / Gearbox - Oil	ADNOC SynGear PA	ADNOC Industrial Gear Oil EP	ISO VG 220, 320, 460
40		Gear Drive / Gearbox - Oil (Worm)	ADNOC SynGear PG	ADNOC Compounded Gear Oil	ISO VG 220, 320, 460
41		Hydraulic	ADNOC Hydraulic Oil HP	ADNOC Hydraulic Oil H	ISO VG 46, 68, 100
42	Blending Silo	Air Compressor	ADNOC Synthetic Compressor Oil PA	ADNOC Compressor Oil	ISO VG 46, 68, 100, 150
43		Fan Blower Bearing - Oil	ADNOC SynGear PA	ADNOC Industrial Gear Oil EP	ISO VG 150, 220

CEMENT - KILN



#	Equipment	Component	Best	Better	Remarks
44	Kiln	Speed Reduction Gearbox	ADNOC SynGear PA	ADNOC Industrial Gear Oil EP	ISO VG 150, 220, 320, 460
45		Electric Motor Bearing	ADNOC Grease PA 220 2	ADNOC Grease EP 2	
46		Plain Bearing - Oil	ADNOC SynGear PA	ADNOC Industrial Gear Oil EP	ISO VG 150, 220
47		Gear Drive / Gearbox - Oil	ADNOC SynGear PA	ADNOC Industrial Gear Oil EP	ISO VG 220, 320, 460
48		Open Gear	ADNOC OGL 22000		OGL Viscosity is ~22000 CSt
49		Bearing - Grease	ADNOC Grease PA 220 2	ADNOC Grease EP 2	
50		Coupling - Grease	ADNOC Grease OGL GAX 1000		OGL Viscosity is ~1000 CSt
51		Support Roller Bearing	ADNOC SynGear PA	ADNOC Industrial Gear Oil EP	ISO VG 320, 460, 680, 1000
52		Tire Roller	ADNOC OGL 22000		OGL Viscosity is ~22000 CSt
53	Cooler	Fan Bearing - Grease	ADNOC Grease LX EP 2	ADNOC Grease EP 2	
54		Bearing - Grease	ADNOC Grease PA 220 2	ADNOC Grease EP 2	
55		Chain	ADNOC Grease PA 220 2	ADNOC Grease EP 2	
56		Electric Motor Bearing	ADNOC Grease PA 220 2	ADNOC Grease EP 2	
57		Gear Drive / Gearbox - Oil	ADNOC SynGear PA	ADNOC Industrial Gear Oil EP	ISO VG 220, 320, 460
58	High Pressure Fan	Fan Bearing - Grease	ADNOC Grease LX EP 2	ADNOC Grease EP 2	
59		Electric Motor Bearing	ADNOC Grease PA 220 2	ADNOC Grease EP 2	

CEMENT - FINISHING



#	Equipment	Component	Best	Better	Remarks
61	Cement Mill	Plain Bearing - Oil	ADNOC SynGear PA	ADNOC Industrial Gear Oil EP	ISO VG 150, 220
62		Gear Drive / Gearbox - Oil	ADNOC SynGear PA	ADNOC Industrial Gear Oil EP	ISO VG 150, 220, 320, 460
63		Open Gear	ADNOC Grease OGL GAX 500		OGL Viscosity is ~500 CSt
64		Trunnion/Thrust/Pinion Bearing	ADNOC SynGear PA	ADNOC Industrial Gear Oil EP	ISO VG 150, 220, 320, 460
65		Fan Bearing - Grease	ADNOC Grease LX EP 2	ADNOC Grease EP 2	
66		Coupling - Grease	ADNOC Grease OGL GAX 1000		OGL Viscosity is ~1000 CSt
67		Speed Reduction Gearbox	ADNOC SynGear PA	ADNOC Industrial Gear Oil EP	ISO VG 150, 220, 320, 460

CEMENT - OTHER AUXILIARY EQUIPMENT



#	Equipment	Component	Best	Better	Remarks
68	Exhaust Fan	Electric Motor Bearing	ADNOC Grease PA 220 2	ADNOC Grease EP 2	
69		Plain Bearing - Oil	ADNOC SynGear PA	ADNOC Industrial Gear Oil EP	ISO VG 150, 220
70	Pneumatic Distribution Systems	Air Compressor	ADNOC Synthetic Compressor Oil PA	ADNOC Compressor Oil	ISO VG 46, 68, 100, 150
71	Conveyor	Gear Drive / Gearbox - Oil	ADNOC SynGear PA	ADNOC Industrial Gear Oil EP	ISO VG 150, 220
72		Gearbox - Grease	ADNOC Grease OGL GAX 500		OGL Viscosity is ~500 CSt
73		Bearing - Grease	ADNOC Grease PA 220 2	ADNOC Grease EP 2	
74	Bucket Elevator	Gear Drive / Gearbox - Oil	ADNOC SynGear PA	ADNOC Industrial Gear Oil EP	ISO VG 150, 220, 320
75		Gearbox - Grease	ADNOC Grease OGL GAX 500		OGL Viscosity is ~500 CSt
76		Bearing - Grease	ADNOC Grease PA 220 2	ADNOC Grease EP 2	
77	Vibrating Screens	Gear Drive / Gearbox - Oil	ADNOC SynGear PA	ADNOC Industrial Gear Oil EP	ISO VG 150, 220
78		Plain Bearing - Oil	ADNOC SynGear PA	ADNOC Industrial Gear Oil EP	ISO VG 150, 220

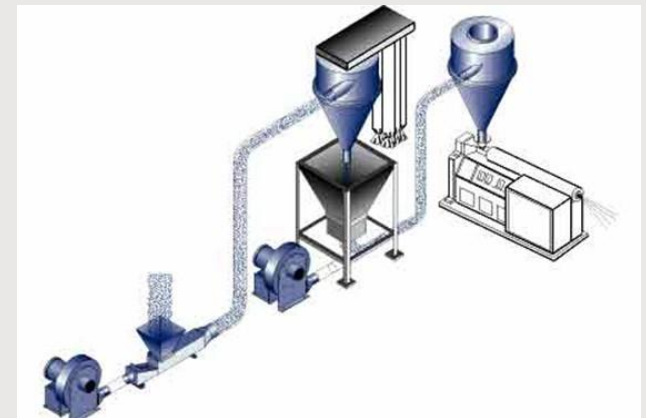

SEGMENT-SPECIFIC LUBRICATION

MINING

MINING INDUSTRY



Extraction



Refining



Finishing

MINING MACHINERIES - EXTRACTION



Lubrication Point	Best	Better
Engine	ADNOC Voyager UltraSyn 10W-40	ADNOC Voyager Plus 15W-40
Transmission & Drivetrain	ADNOC ATF Universal	ADNOC ATF Dexron III-H
Hydraulic	ADNOC Hydraulic Oil HP	ADNOC Hydraulic Oil H
Grease - General	ADNOC Grease PA 220	ADNOC Grease LX EP
Grease – Heavy-Duty / High Loaded	ADNOC Grease Moly EP	
Air Compressor	ADNOC Synthetic Compressor Oil PA	ADNOC Compressor Oil
Differentials & Final Drives	ADNOC HD Trans	
Rock Drill Oil	ADNOC Rock Drilling Oil	

MINING MACHINERIES - REFINING

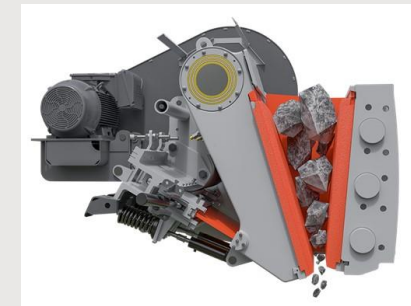
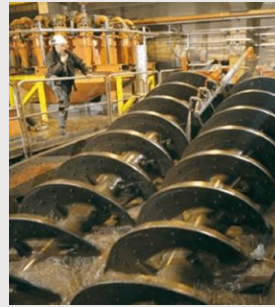

Lubrication Point	Best	Better
Bearing - Oil	ADNOC SynGear PA	ADNOC Industrial Gear Oil EP
Bearing - Grease	ADNOC Grease PA 220 2	ADNOC Grease EP 2
Air Compressor	ADNOC Synthetic Compressor Oil PA	ADNOC Compressor Oil
Coupling - Grease	ADNOC Grease OGL GAX 1000	
Gear Drive / Gearbox - Oil (Worm)	ADNOC SynGear PG	ADNOC Compounded Gear Oil
Gear Drive / Gearbox - Oil	ADNOC SynGear PA	ADNOC Industrial Gear Oil EP
Trunnion/Thrust/Pinion Bearing	ADNOC SynGear PA	ADNOC Industrial Gear Oil EP
Electric Motor Bearing	ADNOC Grease PA 220 2	ADNOC Grease EP 2

MINING MACHINERIES - FINISHING



Lubrication Point	Best	Better
Electric Motor Bearing	ADNOC Grease PA 220 2	ADNOC Grease EP 2
Gear Drive / Gearbox - Oil	ADNOC SynGear PA	ADNOC Industrial Gear Oil EP
Trunnion/Thrust/Pinion Bearing	ADNOC SynGear PA	ADNOC Industrial Gear Oil EP
Bearing - Grease	ADNOC Grease PA 220 2	ADNOC Grease EP 2
Coupling - Grease	ADNOC Grease OGL 5500	
Open Gear	ADNOC OGL 22000	

OTHER TABLES

VISCOSITY – APPLICATION TABLE



ISO VG	Hydraulic	Turbine	Circulating
10	ADNOC Hydraulic Oil H		
15	ADNOC Hydraulic Oil HP (High Performance) ADNOC Hydraulic Oil ZF (Zinc-Free) ADNOC Hydraulic Oil H (Premium)		
22	ADNOC Hydraulic Oil HP (High Performance) ADNOC GII Hydraulic Oil H (Group II base, long life) ADNOC Hydraulic Oil H (Premium)		ADNOC Circulating Oil 22 (Premium)
32	ADNOC Hydraulic Oil HP (High Performance) ADNOC GII Hydraulic Oil H (Group II base, long life) ADNOC Hydraulic Oil ZF (Zinc-Free) ADNOC Hydraulic Oil H (Premium)	ADNOC Turbine Oil AF (Ash-free, Synthetic) ADNOC GII Turbine Oil EP (Group II base + EP, long life) ADNOC GII Turbine Oil (Group II base, long life) ADNOC GRI Turbine Oil (Premium)	ADNOC Circulating Oil 32 (Premium)
46	ADNOC Hydraulic Oil HP (High Performance) ADNOC GII Hydraulic Oil H (Group II base, long life) ADNOC Hydraulic Oil ZF (Zinc-Free) ADNOC Hydraulic Oil H (Premium)	ADNOC Turbine Oil AF (Ash-free, Synthetic) ADNOC GII Turbine Oil EP (Group II base + EP, long life) ADNOC GII Turbine Oil (Group II base, long life) ADNOC GRI Turbine Oil (Premium)	ADNOC Circulating Oil 46 (Premium)
68	ADNOC Hydraulic Oil HP (High Performance) ADNOC GII Hydraulic Oil H (Group II base, long life) ADNOC Hydraulic Oil ZF (Zinc-Free) ADNOC Hydraulic Oil H (Premium)	ADNOC GII Turbine Oil EP (Group II base + EP, long life) ADNOC GII Turbine Oil (Group II base, long life) ADNOC GRI Turbine Oil (Premium)	ADNOC Circulating Oil 68 (Premium)
100	ADNOC Hydraulic Oil HP (High Performance) ADNOC GII Hydraulic Oil H (Group II base, long life) ADNOC Hydraulic Oil ZF (Zinc-Free) ADNOC Hydraulic Oil H (Premium)	ADNOC GII Turbine Oil (Group II base, long life) ADNOC GRI Turbine Oil (Premium)	ADNOC Circulating Oil 100 (Premium)
150	ADNOC Hydraulic Oil H (Premium)		ADNOC Circulating Oil 150 (Premium)

ADNOC HYDRAULIC OIL



* Table for general presentation, refer to products' respective data sheets for appropriate details

PRODUCT NAME	10W	10	15	22	32	46	68	100	150	REMARKS / COMMENTS
ADNOC Hydraulic Oil HP			✓	✓	✓	✓	✓	✓		<ul style="list-style-type: none"> • High Performance • High Viscosity Index in critical applications where viscosity variation due to temperature is critical.
ADNOC Hydraulic Oil ZF			✓		✓	✓	✓	✓		<ul style="list-style-type: none"> • Zinc-free (typical: 10ppm max) • For older design hydraulic pumps containing silver or silver-plated parts. • Moderate to severe conditions in mobile and industrial service • Suitable in environmentally sensitive applications
ADNOC GII Hydraulic Oil H				✓	✓	✓	✓	✓		<ul style="list-style-type: none"> • Group II base oil. • High Oxidation Resistance for longer oil life under severe working conditions
ADNOC Hydraulic Oil H		✓	✓	✓	✓	✓	✓	✓	✓	<ul style="list-style-type: none"> • Premium mineral base oil. • For most types of hydraulic systems, moderately loaded gears and bearing lubricated by circulation bath and ring oiling.
ADNOC Hydraulic Oil HD	✓									<ul style="list-style-type: none"> • Premium mineral base oil. • For general hydraulic applications requiring rust and oxidation inhibited, anti-wear hydraulic fluids